



## GPU 180 kVA · 400Hz

Power	180 kVA
Voltage	115/200Vac
Voltage regulation	± 1%
Power Factor	0,8
Frequency	400Hz
Output 115/200Vac 400Hz	N°2 (90kVA)
Output 28,5Vdc	Option

## ENGINES

- **FPT Stage 0** engine: 18F/180TNE @1846rpm
- **FPT Stage IIIA** engine: 18F/180TE @1846rpm
- **Cummins Stage IIIA** engine: 18C/180TE @1846rpm



HIGH TECHNOLOGY



CERTIFIED QUALITY



USER FRIENDLY CONTROLS

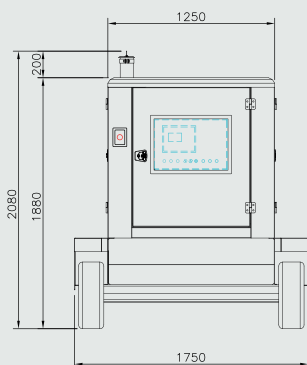
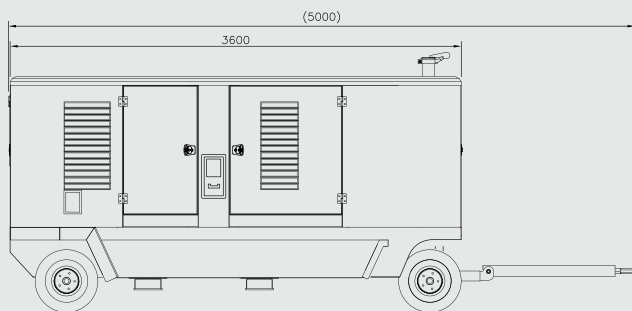

Dimensions are shown in mm



Pictures may not show the actual product due to presence or absence of items



Bertoli provides robust, easy to use and maintain **400Hz diesel ground power units from 60 to 180kVA**. All models feature a user-friendly electronic device for the GPU management through which operators are able to control engine dynamics (low/rated speed, etc.) and energize the desired output(s).

**Sound and weatherproof canopies and trailers are designed and manufactured in-house.**

Special care is devoted to quality of materials and processing. Product look sober and are an optimal matching of essentiality and maximum functionality, conceived to facilitate end users in operating the machine and get the best out of their technical mechanical potential.

## ENGINE

<b>Brand and Model</b>	FPT - NEF67 (stage 0) DEUTZ - TCD2013 (stage III) FPT - NEF67 (stage III) CUMMINS - QSB 8.3 (stage III)
<b>Type</b>	4 stroke, 4 cylinder, turbo with intercooler
<b>Fuel</b>	Diesel
<b>Speed</b>	2000 or 1846 rpm - electronic governor
<b>Cooling</b>	Water cooling with radiator and blower fan
<b>Starting</b>	Electric starting 24Vdc Batteries 2x12Vdc - 140Ah
<b>Sensors</b>	Oil pressure, Water temperature, fuel level, alternator battery charger

## AC OUTPUT

<b>N° of outputs</b>	2 (90kVA each)
<b>Connection</b>	3 phase 4 wire
<b>Voltage</b>	115/200Vac
<b>Frequency</b>	400 Hz
<b>Cables</b>	4x1x70(mm <sup>2</sup> )+4x1, twisted, tinned, extra flexible, length 12 meters
<b>Plug</b>	6 poles, standard rubber type

## DC OUTPUT (ON REQUEST)

<b>N° of outputs</b>	1
<b>Components</b>	Power transformer + rectification circuit "Line drop compensation" electronic device
<b>Voltage</b>	28,5 Vdc
<b>Power output</b>	800A continuous -1200A 90 sec -2400A max 15 sec
<b>Cables</b>	2x120(mm <sup>2</sup> ), tinned, extra flexible, length 12 meters
<b>Plug</b>	3 poles, standard rubber type

## CONFIGURATION

<b>Chassis</b>	Structural steel base equipped with vibration dampers, lifting facilities fitted.
<b>Trailer*</b>	Max dimensions (mm): L3800 x W1900 x H1900. Max weight (kg): 2800 approx. Strong frame in welded steel sections; two axle trailer with steerable front wheels, fix drawbar. Parking brake automatically operated when the draw bar is in vertical position. Cable storage compartment on both sides of GPU with easy access and appropriate size to cable length. Weatherproof. Anticorrosive treatment (on request). RAL 9010 (other colour on request) Large doors for inspection and maintenance Yellow flashing light on top
<b>Canopy</b>	Size signallers. Adjustable service light. Control panel lighting. Interior lighting for maintenance. Sound level 75 dB(A) @ 7m. Fire extinguisher
<b>Fuel tank</b>	Built in the base frame, about 220 litres capacity with cap
<b>Exhaust silencer</b>	Industrial type

\* (Please contact our technical dept. after the order for definitive dimensions and weight)

## TECHNICAL DOCUMENTS

<b>Engine</b>	Operation and maintenance technical manual
<b>Alternator</b>	Operation and maintenance technical manual
<b>Control panel</b>	Wiring diagram Printed label fixed on rear side (under the control panel) for a quick start & use of GPU
<b>GPU</b>	Operation and maintenance manual

## ALTERNATOR

<b>Power</b>	180 kVA
<b>Cos phi</b>	0,8
<b>Authorized overload</b>	110% of rated load for 1 hour in a 6 hours period 300% of rated load for 20sec
<b>Type</b>	24 or 26 poles, single bearing, brushless, self-excited
<b>Mechanical protection</b>	IP 21
<b>Insulation</b>	Class H
<b>Compliance with</b>	Standard BS 2G 219 – EN2292 ISO 6858 MIL-STD-704F
<b>Voltage regulation</b>	Electronic: $\pm 1\%$ (With any power factor and speed variations between -5% and +30%)
<b>Waveform distortion (THD)</b>	1,4% at full load
<b>Engine coupling</b>	Direct

## CONTROL PANEL

<b>Fitting</b>	On the rear side
<b>Protection</b>	IP 54
<b>Electronic device</b>	Programmable electronic device with backlight digital display. All measures are shown by scrolling pages through built-in buttons. Any alarm latched is displayed with description text.
<b>Measure</b>	<b>Engine:</b> oil pressure, water temperature, fuel level, speed, battery voltage, hour counter, alternator battery charger. <b>400Hz output:</b> voltage, frequency, current, power kVA-kVAR-kW, Cosphi (measures phase to phase AND phase to neutral). <b>28Vdc output:</b> voltage, current
<b>Protections: alarms control and automatic shutdown</b>	Pre-configured and editable (through built-in buttons or software) thresholds, each one with its activation delay time: <b>Engine:</b> low oil pressure, high water temperature, low fuel level, overspeed, underspeed, alternator battery charger failure. <b>400Hz output:</b> over/under voltage, over/under frequency, overload, short circuit, phase sequence <b>28Vdc output:</b> over/under voltage, overcurrent (maximum power) with switch
<b>User switches/ buttons</b>	Power supply ON-OFF. START/STOP buttons Min/Max engine speed. Power output activation/deactivation (for each output line) Power output activation forced (permanent output activation, also without feedback from aircraft - plug pins E-F). Alarm acknowledge and reset. Flashing light ON/OFF

## WINTER KIT (ON REQUEST)

<b>Fuel tank</b>	Fuel tank preheating with internal coil for engine water circulator, supplied by 230V, 50Hz external power supply (during storage inside hangars)
<b>Engine</b>	Engine water preheating, supplied by 230V, 50Hz external power supply (during storage inside hangars) Engine air preheating, powered at 24V (during storage inside hangars)
<b>Battery heaters</b>	Battery heater, supplied by 230V, 50Hz external power supply (during storage inside hangars)